

# PLUG-in system



LEADER **IN** INNOVATION

# PLUG-in system

Zero-emission solution options are increased with the Plug-In system

*Con il sistema Plug-In si ampliano le soluzioni a zero emissioni*

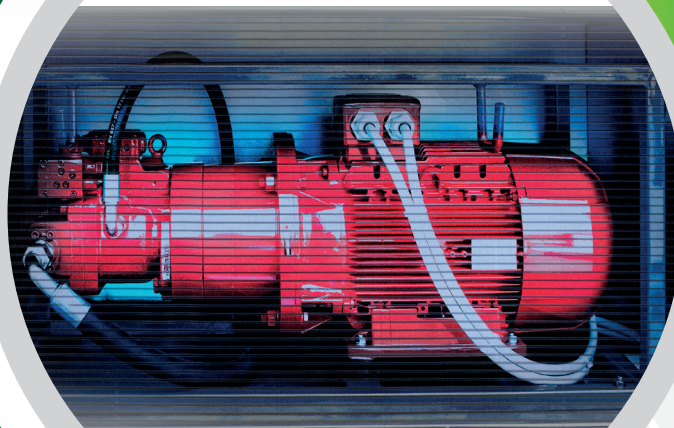

The system consists of a three-phase power-pack integrated into the crane set-up and positioned laterally to the truck and connected whenever it is necessary to work in electric mode.

*Il sistema si compone di un power-pack trifase integrato nell'allestimento che viene posizionato lateralmente al camion e collegato ogni qualvolta si necessita di lavorare in modalità elettrica.*

- Practical, integrated start and stop control panel / *Pratico pannello start and stop integrato*
- For cranes with lifting capacities from 40 tm to 90 tm / *Per gru dalle 40 tm alle 90 tm*
- 380 / 400v three-phase motor / *Motore 380 / 400v trifase*
- 15 kW power / *Potenza 15 kW*
- 32 A
- IP 67 Degree of protection / *Grado protezione IP 67*

## TECHNICAL DRAWING / DISEGNO TECNICO

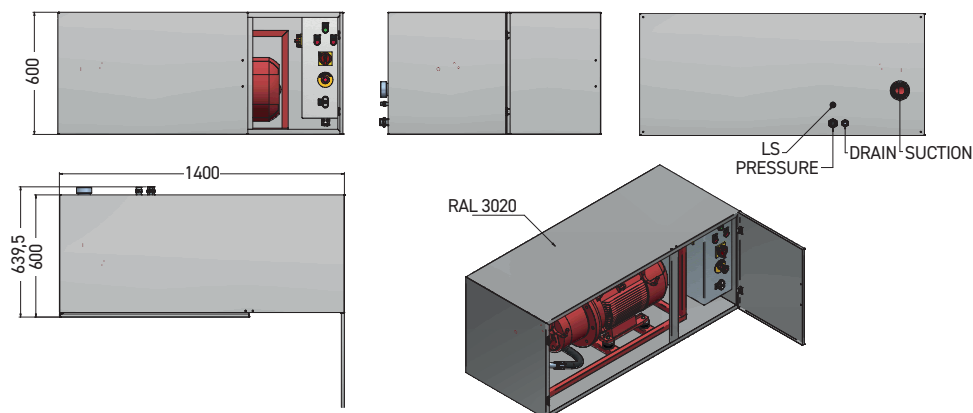

Data and descriptions are approximate and not binding

Realized by Fassi Gru S.p.A. @ 2022 - all right reserved

Reproduction in whole or in part of texts and pictures published on this site on magnetic storage media, digital storage media etc. is prohibited